

# **A Knowledge-Navigation System for Dimensional Metrology**

Howard T. Moncarz  
Intelligent Systems Division (ISD)  
Manufacturing Engineering Laboratory

## **DISCLAIMER**

No approval or endorsement of any commercial product by the National Institute of Standards and Technology is intended or implied. Certain commercial equipment, instruments, or materials are identified in this paper in order to facilitate understanding. Such identification does not imply recommendation or endorsement by the National Institute of Standards and Technology, nor does it imply that the materials or equipment identified are necessarily the best available for the purpose.

This publication was prepared by United States Government employees as part of their official duties and is, therefore, a work of the U.S. Government and not subject to copyright.

# **A Knowledge-Navigation System for Dimensional Metrology**

Howard T. Moncarz  
Intelligent Systems Division (ISD)  
Manufacturing Engineering Laboratory

## **ABSTRACT**

Geometric dimensioning and tolerancing (GD&T) is a method, based on dimensional metrology, to specify a part so that it will meet its design intent. GD&T is difficult to master for two main reasons. First, it is based on complex 3D geometric entities and relationships. Second, the geometry is associated with a large, diverse knowledge base (of dimensional metrology) with many interconnections.

This paper describes an approach to create a dimensional metrology knowledge base that is organized around a set of key concepts and to represent those concepts as virtual objects that can be navigated with interactive, computer visualization techniques to access the associated knowledge.

The approach can enable several applications. First is the application to convey the definition and meaning of GD&T over a broad range of tolerance types. Second is the application to provide a visualization of dimensional metrology knowledge within a control hierarchy of the inspection process. Third is the application to show the coverage of interoperability standards to enable industry to make decisions on standards development and harmonization efforts.

A prototype was implemented to demonstrate the principles involved in the approach.

## **KEYWORDS**

dimensioning and tolerancing, dimensional metrology, knowledge navigation, manufacturing training, VRML

## ACKNOWLEDGMENTS

This work has been supported by intramural funding of the Advanced Technology Program (ATP) of the National Institute of Standards and Technology, in support of the focus area, Adaptive Learning Systems.

## TABLE OF CONTENTS

ABSTRACT.....	iii
KEYWORDS.....	iii
ACKNOWLEDGMENTS.....	iv
TABLE OF CONTENTS.....	v
1      PROBLEM STATEMENT .....	1
2      SOLUTION .....	3
3      SCENARIO .....	7
4      TECHNIQUES .....	9
5      IMPLEMENTATION .....	10
6      DISCUSSION.....	10
7      CONCLUSIONS AND FUTURE WORK.....	12
REFERENCES .....	12



exchanges among the applications to meet particular requirements. The challenge for standards developers is to specify a minimum set of standards to provide coverage for the information exchanges required that will also enable integration for the full range of software applications presently available and likely to be available in the future.

A compilation was made of all of the possible interfaces in the inspection process, and an assessment was made of the standards in place or under development to satisfy those interfaces [Kramer]. (Figure 1 shows the processes and information exchanges that were identified.) The assessment indicated a large tangle of standards that included redundancies and conflicts where the domains of multiple standards overlapped and gaps where there was no coverage at all.

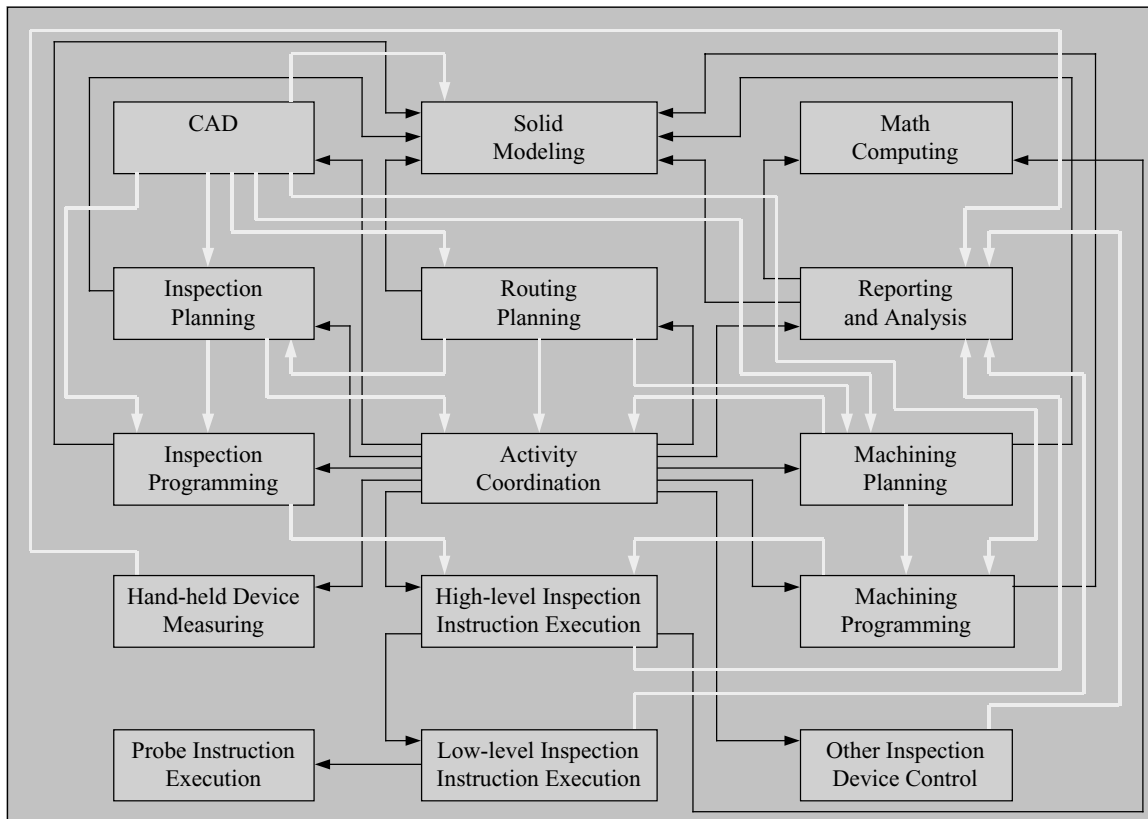

Figure 1: Modules and Interfaces in a Dimensional Metrology System  
Active interfaces shown in black, data interfaces in white

A large store of information is contained in and associated with Kramer's compilation and assessment. It is important to have a clear understanding of that information and its nuances, e.g., why certain information items are specified in certain standards but not in others that seemingly overlap the same processes. A clear communication of the assessment would help industry to prioritize its resources (along with government and academia collaboration) to develop and harmonize the standards required. If that could be accomplished the market for applications supporting the inspection process could grow more efficiently.

**Problem summary:** Dimensional metrology is an important subject but difficult to master for two main reasons. First, it is based on complex 3D geometric entities and relationships. Second, the geometry is associated with a large, diverse knowledge base that has many interconnections. Understanding the knowledge and the interconnections is necessary to master the subject.

This paper presents an approach to address the problem and describes a prototype system that was created to demonstrate the approach.

## 2 SOLUTION

The goal is to provide an intuitive feel for different types of tolerances and to allow an intuitive access to a diverse knowledge base of dimensional metrology information within the familiar context of that domain. This goal leads to a novel approach that combines several aspects. The main idea is to create a knowledge domain that is organized around a set of key concepts and to represent those concepts as virtual objects that can be navigated with interactive computer visualization techniques.

The approach can be applied to the dimensional metrology domain to enable several applications. First is the application to convey the definition and meaning of GD&T over a broad and comprehensive range of that domain as represented by the Y14.5 standard. Second is the application to provide a visualization of dimensional metrology knowledge within a control hierarchy of the inspection process to provide an understanding of that knowledge. Third is the application to show clearly the coverage of interoperability standards within the inspection process to enable industry to make intelligent decisions on standards development and harmonization efforts.

A primary challenge is to choose the key concepts wisely, including their representation as virtual objects. They should be independent from each other (and as orthogonal as possible) and enable a wide and comprehensive coverage of the subject domain. For the concept to be useful in this approach, its virtual representation needs to comprise a decomposition into sub-concepts that distinguishes among information items in the knowledge base at a sufficient resolution to satisfy the applications needed.

The key concepts were chosen to address the applications described above. The concepts are part, tolerance entities, inspection process, interfaces, inspection device, and machining errors. These are described below.

**Part:** The part is the final form of the initial workpiece and has been specified to meet the design intent of the designer for function, manufacturability, etc. The part can be decomposed into features to serve different uses including functionality, manufacturing, inspection, etc. The features can be dimensioned and toleranced, and some features serve as datums.

A collection of parts can be selected such that the features represent a robust collection of manufacturing processes that were used to make them. If the part collection was chosen carefully, many of the dimension types and tolerances specified in Y14.5 could be represented. (Alternatively, one or more test parts could be defined specifically for this collection.) Hence, the part is a main concept that can be associated with a great deal of manufacturing knowledge that is related to GD&T.

The part is represented as a 3D virtual object of its shape. In addition, 2D dimensions and tolerances in Y14.5 symbology can be included as part of the 3D part, and displayed when the 2D view of the part they are associated with is facing to show that view to the user<sup>1</sup> (Figure 2).

**Tolerance entities:** When a tolerance is selected from the part object, the entities associated with that tolerance are displayed. They include the feature toleranced, the datum reference frame or frames (if necessary), the tolerance zone, and the GD&T symbology (of dimensions and feature control frame). The tolerance zone represents a boundary that separates in-tolerance and out-of-tolerance conditions. For example, for a flatness tolerance, the tolerance zone would be the volume between two flat surfaces in 3D space that were spaced on either side of the nominal location of the toleranced surface by a distance of the

---

<sup>1</sup> Any user of the approach or demonstration system described in this paper will be referred to as user whether they are student, practitioner, professional, or other.

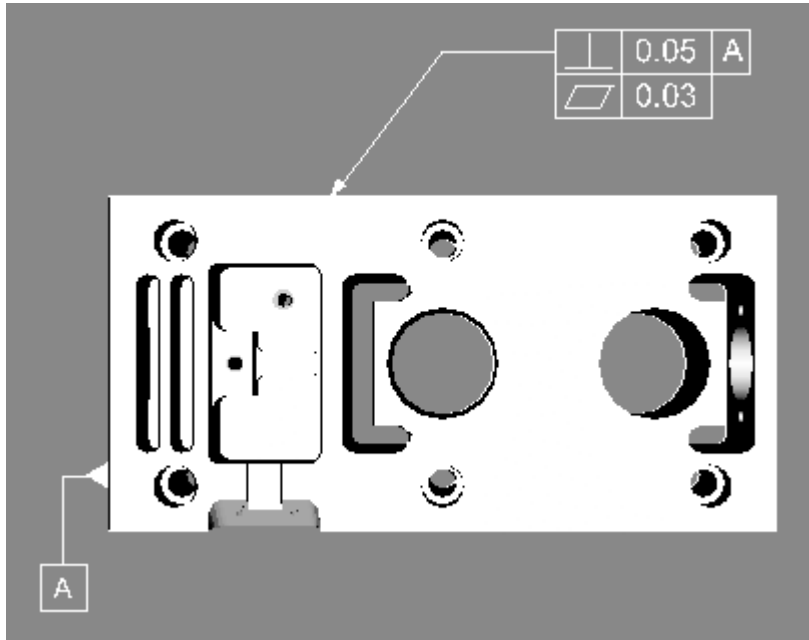

Figure 2: 3D Model of Test Part Oriented to Show Top View

tolerance value specified. The feature control frame succinctly specifies the information that describes the tolerance of the feature (Figure 3). It includes the type of tolerance (e.g., flatness, position, etc.), the tolerance value, the datums that may apply and the material conditions applied. (E.g., maximum material condition, or MMC, is the condition in which a feature of size contains the maximum amount of material within the stated limits of size for example, minimum hole diameter, maximum shaft diameter [ASME, page 3].)

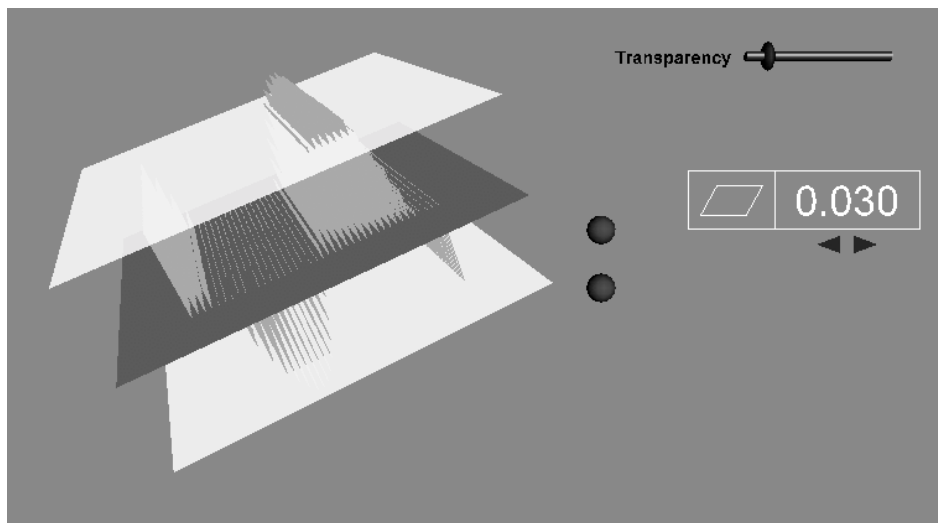

Figure 3: Flatness Tolerance

The feature may be represented as a set of one or more planes and/or cylinders depending on the feature modeled (whether a hole, peg, slot, part side, etc.). Actual (or simulated) measurement points can be plotted in the feature space. The set of feature, tolerance zone, and plotted points can be manipulated together to view the relationships of these entities from any viewpoint. The tolerance zone can be adjusted from invisible to opaque to better view deviations of the feature that cross through the tolerance zone. The feature can be manipulated by the user to wiggle it and see whether the whole feature can fit within the tolerance zone indicating an in-tolerance condition. Also, the tolerance value in the feature control frame can be adjusted which causes a consequent change in the tolerance zone.

By direct interaction with the tolerance entities, the user can obtain an intuitive feel for the meaning of different types of tolerances and how those tolerances are determined. The intuitive feel can be supplemented by displaying appropriate text and diagrams in other frames or windows for the particular tolerance being studied.

**Inspection process:** The control of the inspection process can be represented as a hierarchical task decomposition. That means that a high-level command is decomposed into simpler commands at each successive level of the hierarchy. For example, ISD developed a demonstration implementation of an open-architecture, knowledge-based controller for an inspection workstation (IWS) [Messina]. In IWS, the tasks for the control of the inspection process are decomposed, from the top, as cell, workstation, equipment task, elemental move, primitive, and servo. E.g., a command at the workstation level to inspect a particular part is decomposed, ultimately, to commands to the servo controls of a coordinate measuring machine. In addition to commands and statuses being sent up and down the control hierarchy, data is retrieved and stored at each level, measurements are taken (at the lower levels) and processed up the hierarchy, and value judgements are made to intelligently account and adapt to the measurements taken after comparison with the world view while the inspection is in process. Much of the diverse information involved in the inspection process can be associated with a representation of the task decomposition of the IWS control process.

A 2D diagram can represent the task decomposition and even show the commands, statuses, and data flows, although the density of that information would be great. If you add in the interface standards and attempt to show how they are associated with the already dense information, it is evident that two dimensions are not sufficient to show that information clearly. Consequently, it was decided that three dimensions can show more information and show it more clearly. That thought process was the impetus for the idea of concept planes.

Concept planes is the simple idea of arranging 2D diagrams that are hierarchically structured and related to each other in a stack so that the relationship of a component in one plane relative to a component in another can be inferred by their spatial relationships. The whole stack can be rotated and various components and planes can be made invisible to allow the individual components and spatial relationships among them to be seen. Any component may be selected to display information it is linked to in another frame or window. (Note that 2D boxes in the 2D diagram are represented by 3D boxes in the concept planes so they can be seen as the planes are rotated.)

Three concept planes are used to implement the concept described here for the inspection process (Figure 4). The first plane is a block diagram of the IWS control hierarchy. Six levels are shown as six labeled blocks in a vertical column. Command and status flows are also shown in this plane (though they are left out of the demonstration prototype). At each level the tasks retrieve information from various sources and store processed information back to those or to other repositories. The types of information involved in those information exchanges are shown in the second concept plane. There, the blocks of information are aligned at the same vertical level as the source or destination task. There might be several types of information at any level, and in that case those blocks of information would be arranged side by side. Finally, the third concept plane shows the interface standards. They are arranged and sized to align at the vertical task levels that they are associated with. In other words, if a standard covers information that is exchanged at multiple levels of the IWS hierarchy, its representation is elongated in the vertical plane to show that. (Note that Figure 4 is captured from a screen of the demonstration prototype and does not yet show elongations in the vertical plane for information that spans more than one task level.)

This representation does not have sufficient resolution to compare information exchanges among different standards. Therefore it is used in concert with the next concept, interfaces, for that purpose.

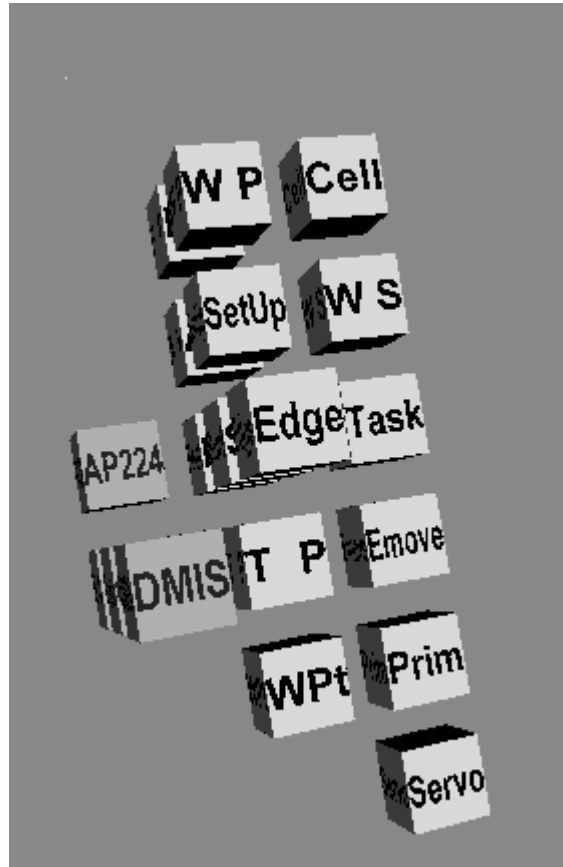

Figure 4: Concept Planes for IWS

**Interfaces:** Figure 1 [Kramer, page 12] shows a different perspective of the information exchange that is based on the functions involved rather than the control levels. These functions are considered from the perspective of producers or users of the information exchanged. E.g., the CAD function feeds data to functions at multiple levels of the control hierarchy. Conversely, the Reporting and Analysis function uses information retrieved from multiple sources up and down the control hierarchy.

This representation may be used in concert with the inspection process representation to explore the information exchanges and compare the differences among the standards in a more intuitive manner than a mere text-based comparison. For example, one of the standards could be selected by clicking on it in the inspection process representation and highlighting the information exchanges involved in the interfaces representation. Conversely, an information producer could be selected in the interfaces representation and the standards affected could be highlighted in the control hierarchy. Using this type of interplay between the two concepts, in addition to displaying information associated with the sub-objects upon command, the user can sift through the large base of data involved more intuitively and with an enhanced understanding produced by seeing it in two different perspectives at once (of the functions involved and the control levels).

**Inspection device:** A coordinate measuring machine (CMM) is an automated inspection device. Seeing a simulation of an inspection rather than an abstract traversal of commands, statuses, and data flows through control levels can enhance the understanding of the whole process. It provides a different perspective of the same information which can appeal to the learning style of some students. Presenting the same information in different styles to the same student is considered a good teaching practice.

This concept is represented by a simple block model of a CMM that can be animated based on user interaction with additional controls and displays provided in the representation. The sub-components of the representation (beyond what is described here) can be used for knowledge associations that include different types of CMMs and probes, calibration knowledge, CMM error sources, etc.

**Machining errors:** This concept covers errors that affect the part result. Sources of machining errors include out-of-calibration machine tools, tool wear, and the environment (e.g., extreme temperatures). Ultimately machining errors show up as an inaccurate part, based on the measured differences between the completed part and the nominal specification. (The part would be incorrect if the differences caused an out-of-tolerance condition.) The errors will often show a distribution pattern that is characteristic of the type of process, the error source, and the type of surface being machined, e.g., a vertical end mill that was out-of-calibration could create lobing errors when machining out a hole. A taxonomy (or other, more complex model) could be created that could connect particular manufacturing error sources to the error patterns created. Conversely, particular error results could be connected back to suspected error sources in the manufacturing process. Thus, a representation, as simple as a taxonomy, could be associated with an empirical database of the information described here.

### 3 SCENARIO

The idea envisioned is that the user would explore objects (concept representations) and study the associated information, interact with the objects to gain intuitive insights, and observe the relationships among different objects. The strategy supports the idea of creating an intuitive framework for this knowledge base in one's mind to understand and retain the information associated with it.

This section provides the author's conception for how this kind of system could be used to explore and study the knowledge base described in Section 1. The treatment is fast paced and brief to provide a flavor of the capabilities rather than a detailed description of them. In the scenario, the user selects the target window ahead of time to display the information files. The target can be a window or the frame of a window; the term window is used to indicate either case. The scenario will first describe the exploration of the GD&T knowledge base; then it will describe the exploration of interoperability standards for the inspection process. Concepts selected by the user are shown in **boldface** in the discussion. Each concept can be set to MOVE mode in which the user can manipulate the position and orientation of the object (representing the concept), or it can be set to INFO mode in which the user can access information by selecting a sub-object.

GD&T: The user calls up the **part** concept into a new window and manipulates it to see its features. Setting the mode to INFO, the mouse is moved over the part. When the mouse is over a feature, the feature is highlighted and a popup text lists a manufacturing process that could make the feature. Scanning the part in this way quickly reveals the types of processes that could make the part. If the mouse is clicked over a feature, a page of information is retrieved and sent to the target information window. That page first lists the manufacturing processes that could make that feature. (Usually more than one process could be used.) Each process identified is a link to further down the page where that process is described, and a discussion is included of why that process would be chosen for the feature selected.

The **machining errors** concept is called up into a new window, and it shows a taxonomy of the type of error distributions that derive from different types of processes with different types of process anomalies. Based on the process chosen in **part**, taxonomy paths are highlighted to show the error sources possible for

that process. Further information about the errors can be accessed by exploring the taxonomy and clicking sub-objects of it to call up information pages associated with those taxonomy items.

Going back to **part**, the user selects the GD&T option which causes the Y14.5 dimensions and tolerancing symbology to be visible on the part display. The symbology is connected to the 2D views of the part (top, front, etc.) and rotates along with the part as the part is rotated. If the front face is rotated to the back, the GD&T symbology associated with the front face is no longer visible. The user clicks on one of the tolerance feature control frames, and the **tolerance entities** concept for that tolerance is called up into a new window.

The tolerance entities include the feature set toleranced (usually one feature), the datums, the tolerance zone and the feature control frame. The feature set shows the nominal surfaces and can be manipulated to see its various positions and orientations that will still keep it within the tolerance zone and consequently in tolerance. The tolerance value is connected to the tolerance zone and a change in either affects the other. Insights may be particularly valuable when looking at, for example, a positional tolerance that is located by one or more datums and material conditions are specified. E.g., if a hole datum is modified by the maximum material condition (MMC), it affects the position of the tolerance zone of a hole that is referenced to that datum. By changing material conditions and tolerance values for different types of tolerances, considerable insights can be gained for the meaning of those tolerances.

Returning to the **machining errors** concept, the error factors associated with different processes can be changed and the resultant error patterns displayed (as whiskers on a surface, with the magnified lengths of each representing the deviation from the nominal surface). These error patterns can be sent to the **tolerance entities** concept to be superimposed on the feature toleranced. The user can obtain further insights by interacting with the tolerance entities as before and observing how different types of errors have different impacts on different tolerances. Note that the tolerance zone can be changed from invisible to opaque, the latter used to better observe the errors crossing the tolerance zone for out of tolerance conditions when the feature is wiggled to scope out the limits of the tolerance zone.

Interoperability Standards: To explore interoperability standards the user calls up the **inspection process** concept. By manipulating and scanning over the concept planes, the relationships of tasks, data, and standards can be observed in the context of the hierarchical control system for the inspection process. Clicking on any of the sub-concepts will call up a page of information about it; e.g., clicking on any of the standards will provide a page that briefly describes the standard. Clicking on an information block at the same level will show the type of information the standard will cover (at least in part).

A full description of the information exchanges covered by the standard requires the user to call up the **interfaces** concept in a new window. When a standard is selected in the inspection process, the corresponding functions and information exchanges are highlighted in the interfaces concept. Clicking on any of the highlighted boxes or data arrows in that concept will show the information exchanged and its format for the standard selected. Calling up a second **interfaces** concept in a new window will put that concept in focus and a new standard selected in the **inspection process** will highlight the information exchanges for that standard in the new interfaces window. Then the standards can be compared side by side. Any information overlaps will be highlighted in a different color in both **interfaces** windows.

Finally, the user goes back to the **part** concept and sets its mode to INFO. When any part feature is selected the data representation of the standard selected in the **inspection process** for the feature selected will appear in the target information window. For example, if DMIS is selected in the inspection process, clicking on a part feature will send the DMIS file (of instructions to inspect that feature) to the target display window. By exploring interactively among these three concepts (inspection process, interfaces, and part) a large amount of information can be explored quickly and in a context to promote understanding and retention of it. (Note that some standards affect other concepts, e.g., DMIS commands can be executed by the CMM, an **inspection device**, and calling up that concept can be further illustrative of the information exchanges, what they mean, and how they are used.)

The approach and scenario can be implemented with the techniques described below.

Virtual objects: The main interface to the knowledge base is a virtual object (in 2D or 3D) which is the representation of a concept. The object is decomposable into sub-objects, reflecting the concept's decomposition. Each sub-object can be linked to different types of information depending on which type has been set for that object. The virtual object might represent a physical object, e.g., a machined part; or it might represent an abstract concept, e.g., an inspection process where the separate applications of the process are represented by a set of boxes. For the latter case, the sub-objects are the boxes. However, a machined part is comprised of features that, for the most part, are created by volume-removal operations. In this case the features are the sub-objects.

The Virtual Reality Modeling Language (VRML) was used to create the virtual objects in the prototype demonstration created. VRML is not designed to represent a boolean subtraction (such as a volume removal). Therefore, for a physical object a technique was developed to superimpose a set of transparent surfaces that represent each feature on top of a solid model of the object. The information needed for a particular object is derived from a STEP AP224 file [ISO224], which is based on a standard that specifies the individual features of an object as well as the entire object.

When a sub-object is selected, two signals are sent out. The first identifies the parent object and the second the sub-object. Another object can be wired to receive those signals. That object can take two actions. It can set its information state, e.g., to specify what type of information to display when its own sub-objects are selected; or, it can take an action based on the signal, e.g., to display information based on the signal received and its previously set mode. Finally, all objects have a mode that is set to MOVE or INFO. In the MOVE mode, the object can be manipulated by the mouse (as described below under object manipulation). In the INFO mode, a mouse click on a sub-object will link to information that can be displayed in another window.

Multi-modal info popup: When an object is in INFO mode, a mouseover of a sub-object will cause it to be highlighted and a popup caption, based on the information mode set, to be displayed. With this capability an object can be quickly scanned to see what types of information are associated with its sub-objects. For example, if the part object's INFO type was set to manufacturing process, a mouseover of a feature would display a popup that listed a manufacturing process that could make it. (If the feature was selected by a mouse click, detailed information about the manufacturing process associated with that feature could be displayed.)

Knowledge search: This system can be used to access information that is analogous to specifying a value for one or more key fields of a database to retrieve the pertinent information record sought. In this system, the concepts are analogous to the key fields and each concept includes a range of values that can be selected (i.e., the sub-concepts). Visualize several of these concepts displayed on the screen (as their object representations) with the value selected for each (i.e., the appropriate sub-object) highlighted. In other words, each key field value chosen is shown in the context of the broader concept of which it is a component. Consequently, the key-field values chosen specify an item in the knowledge base. Reiterating a point made previously, the degree of decomposition of concepts into sub-concepts determines the resolution of this system to distinguish among the items stored in the knowledge base.

User-selectable information display: The goal is to allow the user to explore the knowledge base with the main attention focused on the task at hand to study the objects on the screen and pull up additional information as needed. The user should be able to direct that information to a window at any place on the screen, and have the flexibility to arrange multiple information windows as desired. At times the user might want to compare two pieces of information in two, side-by-side windows, e.g., two different representations of the same information from two different standards.

The flexibility described here should also apply to the virtual objects that represent concepts. The user should have the flexibility to place these in separate windows or group several of these objects in the same

window. In either case, the objects should be able to communicate their signals to each other as specified above in virtual objects. The flexibility in placing these objects is partially enabled by the technique discussed next.

Object manipulation and visibility controls: This capability is necessary to position objects for feature access and visibility on an object by object basis, i.e., to selectively manipulate one of multiple objects on the screen at one time and to selectively render certain sub-objects as invisible to reveal other sub-objects hidden by the former in a particular view. The technique employed should be easy to use and unobtrusive so the user can focus on the task at hand and not the manipulator.

The technique used places a small mode-control object near the object to be controlled. The mode control can be toggled to different shapes, and consequently different modes, by clicking it. The shapes and respective modes represented are a three-dimensional arrow for translation, a cylinder for a cylindrical rotation, a sphere for a spherical rotation, and a cube for a scaling operation.

Concept planes: This technique was described in Section 2 when the inspection-process concept was explained.

## 5 IMPLEMENTATION

The computer system used for this work was minimal. The computer was a 300 MHz PC compatible with 128 MB of RAM. It would be considered at the low end for typical systems sold today. The system software used included the Windows 95 Operating System and a web browser either the Netscape Communicator 4.5 or the Microsoft Internet Explorer 5.5 (both were used in this project).

Because this project depends on 3D virtual objects, it was decided to use the Virtual Reality Modeling Language (VRML) to specify (i.e., model) them. VRML is a standard and a scene description language used to represent three-dimensional scenes that contain objects and their behaviors (including interactive behaviors among the objects as well as with the user) over the web. (At the end of 1997, VRML97 became an official ISO standard.) To utilize VRML for this work a VRML plug in to the browser was installed. The plug in used was Cortona VRML Client 2.2 from ParallelGraphics, and is available as a free download from their web site ([www.parallelgraphics.com](http://www.parallelgraphics.com)).

The software development system consisted of two tools, FrontPage 2000 from Microsoft Corporation for web page development and VrmIpad from ParallelGraphics for creation of the VRML objects. The VRML objects included text, 3D objects, and 2D objects. JavaScript was used within the VRML Script Nodes to create the behaviors needed for the objects.

The demonstration prototype implements five of the concepts described (although, not to the full extent described in Sections 2 and 3). The concepts implemented are part, tolerance entities, inspection process, interfaces, and inspection device. The concept of machining errors has not yet been implemented at the time of this paper. Furthermore, the techniques described in Section 4 were implemented to a partial but not full extent. A notable difference is that the ability to communicate from one object in a window to another object in a different window (or frame) was not implemented. To demonstrate the communication between objects, they are shown in the same window (and frame). Another significant difference is that the positional tolerance described in the Scenario (Section 3), including the material conditions, was not implemented. (Simpler tolerances, such as flatness, have been implemented.) There are other, smaller differences that are not listed here.

## 6 DISCUSSION

This section discusses the overall idea in terms of its novelty and then discusses issues concerning the web technologies needed for implementing the techniques required.

**Uniqueness of the approach:** This is a new approach to communicate the meaning of GD&T and the inspection process, including a visualization of the coverage of information exchanges in interoperability standards. That is not to say that any of these ideas have never been used before. In fact, there are commercial products available that incorporate sophisticated 3D modeling, animation, and programming of the CMM inspection process. There are products available that provide online training for geometric dimensioning and tolerancing in a multi-media format. (I do not know of any products that help in the understanding of information exchanges in the perspective of interoperability standards, however.)

The novelty of this approach is in the entirety of the ideas it integrates, and particular aspects of it as listed below:

- organizing the dimensional metrology domain space into main concepts that are represented by virtual objects that can be manipulated and examined;
- the particular set of concepts chosen to represent a portion of the dimensional metrology domain;
- decomposing the main concepts into sub-concepts whose virtual-object representation is associated with information from the domain knowledge base;
- the interactivity of the tolerance-entities concept and the combination of ideas it integrates together i.e., how tolerance zones are affected by varying the tolerance value, the modifier (such as material condition), and the type of error pattern (based on the manufacturing process);
- some particular methods for implementing the approach (e.g., using AP224 to create transparent features that are superimposed on a 3D model that can be selected and are linked to other information, concept planes, etc.);
- and finally, the implementation of the idea on the web using standardized technologies.

**Web technologies:** The goal of this project was to use as broad a platform (i.e., open architecture and standards based) as possible for maximum dissemination. Consequently, it was decided to make this work accessible via the web and to use techniques that employ standards that have been endorsed by the World Wide Web Consortium (W3C) [[www.w3.org](http://www.w3.org)].

As mentioned above, VRML is a standard that can be used to specify 3D objects. It can also be used to specify text and 2D objects. In fact, the capability to specify text, 2D, and 3D objects combined together in the same scene (and hence in the same window) was used in this project. However, it would be useful to present some or all of the concept representations in their own windows. Then the screen space for the whole set of concepts displayed, including the additional information associated with various concepts and displayed in additional windows, could be managed with one generic set of functions. For example, the user could drag, scale, or stack the windows throughout the screen space as desired, and could rearrange those easily during a session. The problem is that, with the current technology, it is difficult, awkward, and unreliable to access an attribute of a VRML object in one window from another because multiple software interfaces need to be crossed to do so.

In addition, VRML creates an isolated environment from models created elsewhere (e.g., HTML pages and 2D or 3D models created with other authoring systems) in that a VRML world operates in a VRML browser and can only access other objects through multiple interfaces as described above. The solution, as implemented for this project, is to create the text and 2D objects with the VRML constructs available. However, these are limited (insofar as what is available outside VRML), are inefficient (using 3D constructs to create 2D objects), and are sometimes difficult to program (e.g., creating the 2D Y14.5 objects as VRML constructs).

However, solutions are on the horizon. New web technologies, including a next-generation VRML standard, are due out shortly that should solve the problems mentioned above. The goal of the next generation of web standards and technologies will allow page elements (such as text, images, 2D and 3D objects, windows, frames, etc.) to be used very flexibly together, and all accessible through a script-based language such as JavaScript.

## 7 CONCLUSIONS AND FUTURE WORK

This paper presented a new approach to convey understanding of dimensional metrology, in particular, geometric dimensioning and tolerancing and interoperability standards for the inspection process. The approach uses computer visualization to navigate a knowledge domain organized around key concepts represented by 2D and 3D virtual objects. A prototype demonstration was created to illustrate the ideas and techniques presented. Though the approach was applied to dimensional metrology it could be applied to other domains as well; domains involving complex geometric entities and relationships are particularly well suited.

The demonstration can better illustrate the ideas presented but is not sufficient to judge the approach for enhanced understanding of dimensional metrology. Before that can be achieved, the techniques need to be reimplemented with new (standards-based) web technologies that will allow greater flexibility in integrating web-page elements that include text, 2D and 3D objects, and windows and window frames. Those technologies are anticipated within the next year or two. In addition, sufficient content needs to be added to demonstrate a real application. A full GD&T application would take considerable development work; there are many concepts to demonstrate and each one requires substantial design and development effort. Extending further, a demonstration that showed the interactions of more than one tolerance of a part on each other would be very insightful to understanding GD&T but would be proportionately more difficult to implement. The application for interoperability standards would need further design and development to flesh out, but would be a considerably easier job. Afterwards, comprehensive content would need to be included.

In closing, I d like to make a recommendation for the development of a taxonomy for dimensional metrology that could be standardized. That would be an important step in putting the subject online, because it would encourage the development of a distributed knowledge base that could be accessed by multiple applications, reducing the risk to the developers. The ideas presented here for organizing the knowledge domain are offered for that effort.

## REFERENCES

- [ASME] *Dimensioning and Tolerancing, ASME Y14.5M-1994* [Revision of ANSI Y14.5M-1992 (R1988)], The American Society of Mechanical Engineers, 345 East 47<sup>th</sup> Street, New York, N.Y., 1995.
- [Busch] Busch, Ted, *Fundamentals of Dimensional Metrology*, Second Edition, Delmar Publishers Inc., Albany, NY, 1989.
- [ISO224] ISO 10303-224:1998, *Industrial automation systems and integration — Product data representation and exchange — Part 224: Application Protocol: Mechanical Product Definition for Process Planning Using Machining Features*, ISO, Geneva, Switzerland, 1998.
- [Kramer] Kramer, Tom, et al, *Analysis of Dimensional Metrology Standards*, National Institute of Standards and Technology, Gaithersburg, MD, to be published as a NISTIR in 2001.
- [Messina] Messina, E., Horst, J., Kramer, T., Huang, H., Tsai, T., and Amatucci, E., "A Knowledge-Based Inspection Workstation," Proceedings of the 1999 IEEE International Conference on Information, Intelligence, and Systems, November 1999.
- [Zolnai] Zolnai, Dave, Understanding Y14.5, *Quality*, Bensenville, IL, May 2001.